



Disclaimer:
 The planimetric and topographic information depicted on this map was compiled by The Seaborn Map Company based on an aerial flight on or about 4/14/2017. The parcel and property line information depicted on this map has been compiled from recorded deeds, maps, a tax parcel records, and other sources of information in the Town of Groton. The intent of this map is to depict a graphical representation of real property information related to the planimetric features for the Town of Groton and is subject to change as a more accurate survey may disclose. The Town of Groton and the mapping companies assume no legal responsibility for the information contained in this data.
THIS MAP IS NOT TO BE USED FOR THE TRANSFER OF PROPERTY.
 Horizontal Datum:
 Connecticut State Plane Coordinates, North American Datum of 1983 (NAD83 Feet)
 Vertical Datum:
 North American Vertical Datum of 1988 (NAVD88)

Town of Groton 240 ORAL SCHOOL RD



Date: 4/24/2017

Commercial Property Card

Print Date: 4/24/2017

Card 1 of 6

<<Back Next>>

Account 261906386767 E	Location 240 ORAL SCHOOL RD	Zoning RU-80	Deed Book/Page 90/426	Acres 77.39
District OLD MYSTIC	Use Code STATE			

Current Owner

CONNECTICUT STATE OF MYSTIC ORAL SCHOOL
9 ORAL SCHOOL RD
MYSTIC CT 06355

Property Picture



Building Information

Building No: 1
Year Built: 1976
No of Units: 1
Structure Type: CULTURAL FACILITY
Building Total Area: 51929 sqft.
Grade: B-
Identical Units: 1

Valuation

Land: \$1,554,000
Building: \$15,040,400
Total: \$16,594,400
Total Assessed Value: \$11,616,080

Recent Sales

Book/Page	Date	Price
-----------	------	-------

Building Sketch

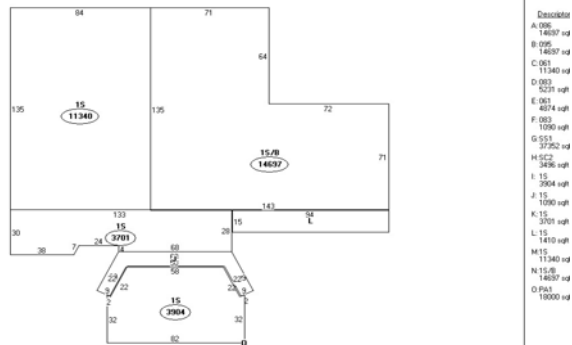

Sketch Legend

-----	Main Living Area	1SMA	Masonry	GRHS	Attached Greenhouse
1FR	Frame	OMP	Open Masonry Porch	CAT	Cathedral Ceiling
OFF	Open Frame Porch	EMP	Enclosed Msry Porch	SOP	Screen Open Frame Prch
EFP	Enclosed Frame Porch	MUB	Masonry Utility	SMP	Screen Open Msry Prch
FUB	Frame Utility Building	MB	Masonry Bay	CPAT	Concrete Patio
FB	Frame Bay	MOH	Masonry Overhang	B	Basement
FG	Frame Garage	.SMA	1/2 Story Masonry		
FOH	Frame Overhang	MP	Masonry Patio		
.SFR	1/2 Story Frame	WD	Wood Deck		
A(U)	Attic (Unfinished)	CPY	Canopy		
A(F)	Attic (Finished)				

Exterior/Interior Information

Levels	Use Type	Ext. Walls	Const. Type	Heating	A/C	Condition
B1 - B1	SUPPORT AREA	N/A	FIRE RESIST	NONE	NONE	NORMAL
01 - 01	COVERED MALL	BRICK VENEER	FIRE RESIST	HOT AIR	CENTRAL	NORMAL
01 - 01	AUDITORIUM/THEATER	BRICK	FIRE RESIST	HOT AIR	CENTRAL	NORMAL

		VENEER				
01 - 01	MULTI-USE SALES	BRICK VENEER	FIRE RESIST	HOT AIR	CENTRAL	NORMAL
01 - 01	AUDITORIUM/THEATER	BRICK VENEER	FIRE RESIST	HOT AIR	CENTRAL	NORMAL
M1 - M1	MULTI-USE SALES	ENCLOSURE	WOOD JOIST	HOT AIR	CENTRAL	NORMAL
01 - 01	WAREHOUSE	CONCRETE BLOCK	FIRE RESIST	NONE	NONE	FAIR
01 - 01	WAREHOUSE	BRICK VENEER	FIRE RESIST	NONE	NONE	FAIR
B1 - B1	SUPPORT AREA	N/A	FIRE RESIST	HW/STEAM	NONE	NORMAL
01 - 01	MULTI-USE OFFICE	BRICK VENEER	FIRE RESIST	HW/STEAM	NONE	NORMAL
02 - 03	MULTI-USE OFFICE	BRICK VENEER	FIRE RESIST	HW/STEAM	NONE	NORMAL
B1 - B1	MULTI-USE OFFICE	N/A	FIRE RESIST	HW/STEAM	NONE	NORMAL
01 - 01	MULTI-USE OFFICE	BRICK VENEER	FIRE RESIST	HW/STEAM	NONE	NORMAL
02 - 02	MULTI-USE APARTMENT	BRICK VENEER	FIRE RESIST	HW/STEAM	NONE	NORMAL
01 - 01	SCHOOL	BRICK VENEER	FIRE RESIST	HW/STEAM	NONE	NORMAL
02 - 02	SCHOOL	BRICK VENEER	FIRE RESIST	HW/STEAM	NONE	NORMAL
B1 - B1	MULTI-USE STORAGE	N/A	FIRE RESIST	HW/STEAM	NONE	NORMAL
B1 - B1	SCHOOL	N/A	FIRE RESIST	HW/STEAM	NONE	NORMAL
01 - 01	CATERERIA	BRICK VENEER	FIRE RESIST	HW/STEAM	NONE	NORMAL
01 - 01	MULTI-USE OFFICE	BRICK VENEER	FIRE RESIST	HW/STEAM	NONE	NORMAL
02 - 02	MULTI-USE OFFICE	BRICK VENEER	FIRE RESIST	HW/STEAM	NONE	NORMAL
02 - 02	MULTI-USE OFFICE	BRICK VENEER	FIRE RESIST	HW/STEAM	NONE	NORMAL
03 - 03	MULTI-USE OFFICE	BRICK VENEER	FIRE RESIST	HW/STEAM	NONE	NORMAL
B1 - B1	LIGHT MANUFACTURING	N/A	FIRE RESIST	HW/STEAM	CENTRAL	
B1 - B1	UNFINISHED RES BSMT	N/A	WOOD JOIST	NONE	NONE	NORMAL
01 - 01	DWELLING	BRICK VENEER	WOOD JOIST	HW/STEAM	NONE	NORMAL
02 - 02	DWELLING	BRICK VENEER	WOOD JOIST	HW/STEAM	CENTRAL	NORMAL
A1 - A1	SUPPORT AREA	BRICK VENEER	WOOD JOIST	NONE	NONE	FAIR
01 - 01	SCHOOL	BRICK VENEER	FIRE RESIST	HW/STEAM	NONE	FAIR
02 - 02	DORMITORY	BRICK VENEER	FIRE RESIST	HW/STEAM	NONE	NORMAL
01 - 01	CATERERIA	BRICK VENEER	FIRE RESIST	HW/STEAM	CENTRAL	GOOD
B1 - B1	MULTI-USE OFFICE	N/A	FIRE RESIST	HW/STEAM	CENTRAL	NORMAL
B1 - B1	SCHOOL	N/A	FIRE RESIST	HW/STEAM	NONE	POOR
01 - 01	DORMITORY	BRICK VENEER	FIRE RESIST	HW/STEAM	CENTRAL	GOOD
01 - 01	DORMITORY	BRICK VENEER	FIRE RESIST	HW/STEAM	NONE	FAIR

Commercial Property Card

Print Date: 4/24/2017

Card 2 of 6

<<Back Next>>

Account	Location	Zoning	Deed Book/Page	Acres
261906386767 E	240 ORAL SCHOOL RD	RU-80	90/426	77.39
District	Use Code			
OLD MYSTIC	STATE			

Current Owner

CONNECTICUT STATE OF MYSTIC ORAL SCHOOL
 9 ORAL SCHOOL RD
 MYSTIC CT 06355

Property Picture



Building Information

Building No:	2
Year Built:	1961
No of Units:	1
Structure Type:	WAREHOUSE
Building Total Area:	7728 sqft.
Grade:	B-
Identical Units:	1

Valuation

Land:	\$1,554,000
Building:	\$15,040,400
Total:	\$16,594,400
Total Assessed Value:	\$11,616,080

Recent Sales

Book/Page	Date	Price
-----------	------	-------

Building Sketch

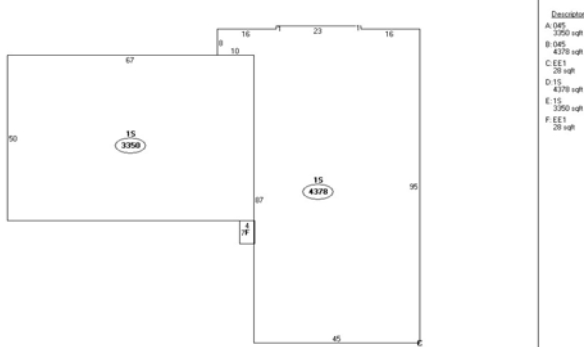

Sketch Legend

-----	Main Living Area	1SMA	Masonry	GRHS	Attached Greenhouse
1FR	Frame	OMP	Open Masonry Porch	CAT	Cathedral Ceiling
OFF	Open Frame Porch	EMP	Enclosed Msry Porch	SOP	Screen Open Frame Prch
EFP	Enclosed Frame Porch	MUB	Masonry Utility	SMP	Screen Open Msry Prch
FUB	Frame Utility Building	MB	Masonry Bay	CPAT	Concrete Patio
FB	Frame Bay	MOH	Masonry Overhang	B	Basement
FG	Frame Garage	.SMA	1/2 Story Masonry		
FOH	Frame Overhang	MP	Masonry Patio		
.SFR	1/2 Story Frame	WD	Wood Deck		
A(U)	Attic (Unfinished)	CPY	Canopy		
A(F)	Attic (Finished)				

Exterior/Interior Information

Levels	Use Type	Ext. Walls	Const. Type	Heating	A/C	Condition
01 - 01	WAREHOUSE	CONCRETE BLOCK	FIRE RESIST	NONE	NONE	FAIR
01 - 01	WAREHOUSE	BRICK VENEER	FIRE RESIST	NONE	NONE	FAIR

Commercial Property Card

Print Date: 4/24/2017

Card 3 of 6

<<Back Next>>

Account	Location	Zoning	Deed Book/Page	Acres
261906386767 E	240 ORAL SCHOOL RD	RU-80	90/426	77.39
District	Use Code			
OLD MYSTIC	STATE			

Current Owner

CONNECTICUT STATE OF MYSTIC ORAL SCHOOL
 9 ORAL SCHOOL RD
 MYSTIC CT 06355

Property Picture



Building Information

Building No:	3
Year Built:	1961
No of Units:	3
Structure Type:	SCHOOL
Building Total Area:	53970 sqft.
Grade:	C+
Identical Units:	1

Valuation

Land:	\$1,554,000
Building:	\$15,040,400
Total:	\$16,594,400
Total Assessed Value:	\$11,616,080

Recent Sales

Book/Page	Date	Price
-----------	------	-------

Building Sketch

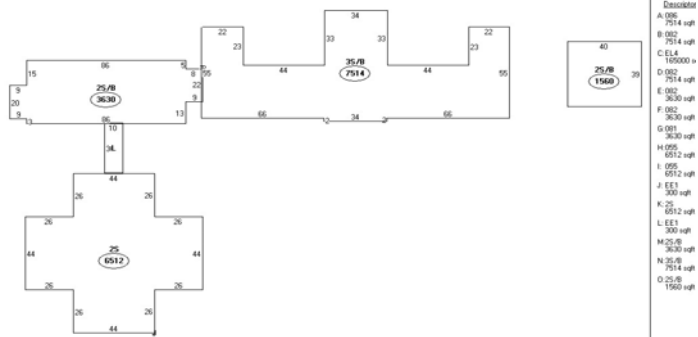

Sketch Legend

-----	Main Living Area	1SMA	Masonry	GRHS	Attached Greenhouse
1FR	Frame	OMP	Open Masonry Porch	CAT	Cathedral Ceiling
OFF	Open Frame Porch	EMP	Enclosed Msry Porch	SOP	Screen Open Frame Prch
EFP	Enclosed Frame Porch	MUB	Masonry Utility	SMP	Screen Open Msry Prch
FUB	Frame Utility Building	MB	Masonry Bay	CPAT	Concrete Patio
FB	Frame Bay	MOH	Masonry Overhang	B	Basement
FG	Frame Garage	.SMA	1/2 Story Masonry		
FOH	Frame Overhang	MP	Masonry Patio		
.SFR	1/2 Story Frame	WD	Wood Deck		
A(U)	Attic (Unfinished)	CPY	Canopy		
A(F)	Attic (Finished)				

Exterior/Interior Information

Levels	Use Type	Ext. Walls	Const. Type	Heating	A/C	Condition
B1 - B1	SUPPORT AREA	N/A	FIRE RESIST	HW/STEAM	NONE	NORMAL
01 - 01	MULTI-USE OFFICE	BRICK VENEER	FIRE RESIST	HW/STEAM	NONE	NORMAL
02 - 03	MULTI-USE	BRICK	FIRE RESIST	HW/STEAM	NONE	NORMAL

	OFFICE	VENEER				
B1 - B1	MULTI-USE OFFICE	N/A	FIRE RESIST	HW/STEAM	NONE	NORMAL
01 - 01	MULTI-USE OFFICE	BRICK VENEER	FIRE RESIST	HW/STEAM	NONE	NORMAL
02 - 02	MULTI-USE APARTMENT	BRICK VENEER	FIRE RESIST	HW/STEAM	NONE	NORMAL
01 - 01	SCHOOL	BRICK VENEER	FIRE RESIST	HW/STEAM	NONE	NORMAL
02 - 02	SCHOOL	BRICK VENEER	FIRE RESIST	HW/STEAM	NONE	NORMAL

Commercial Property Card

Print Date: 4/24/2017

Card 4 of 6

<<Back Next>>

Account	Location	Zoning	Deed Book/Page	Acres
261906386767 E	240 ORAL SCHOOL RD	RU-80	90/426	77.39
District	Use Code			
OLD MYSTIC	STATE			

Current Owner

CONNECTICUT STATE OF MYSTIC ORAL SCHOOL
 9 ORAL SCHOOL RD
 MYSTIC CT 06355

Property Picture



Building Information

Building No:	4
Year Built:	1961
No of Units:	2
Structure Type:	SCHOOL
Building Total Area:	71736 sqft.
Grade:	C+
Identical Units:	1

Valuation

Land:	\$1,554,000
Building:	\$15,040,400
Total:	\$16,594,400
Total Assessed Value:	\$11,616,080

Recent Sales

Book/Page	Date	Price
-----------	------	-------

Building Sketch

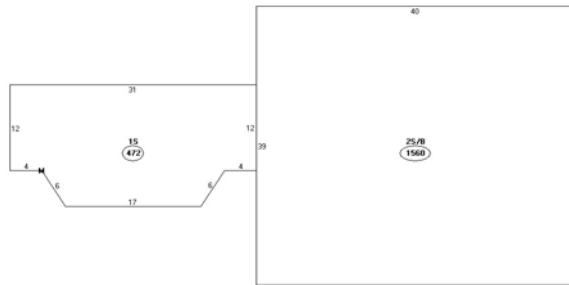

Descriptor
 A.004 0725 sqft
 B.005 2516 sqft
 C.007 5396 sqft
 D.002 19971 sqft
 E.002 2540 sqft
 F.002 16429 sqft
 G.002 6540 sqft
 H.044 6339 sqft
 I.014 40000 sqft
 J.014 25000 sqft
 K.001 65 sqft
 L.006 77 sqft
 M.003 77 sqft
 N.15 472 sqft
 O.05.06 1960 sqft

Sketch Legend

----- Main Living Area	1SMA Masonry	GRHS Attached Greenhouse
1FR Frame	OMP Open Masonry Porch	CAT Cathedral Ceiling
OFF Open Frame Porch	EMP Enclosed Msry Porch	SOP Screen Open Frame Prch
EFP Enclosed Frame Porch	MUB Masonry Utility	SMP Screen Open Msry Prch
FUB Frame Utility Building	MB Masonry Bay	CPAT Concrete Patio
FB Frame Bay	MOH Masonry Overhang	B Basement
FG Frame Garage	.SMA 1/2 Story Masonry	
FOH Frame Overhang	MP Masonry Patio	
.SFR 1/2 Story Frame	WD Wood Deck	
A(U) Attic (Unfinished)	CPY Canopy	
A(F) Attic (Finished)		

Exterior/Interior Information

Levels	Use Type	Ext. Walls	Const. Type	Heating	A/C	Condition
B1 - B1	MULTI-USE STORAGE	N/A	FIRE RESIST	HW/STEAM	NONE	NORMAL
B1 - B1	SCHOOL	N/A	FIRE RESIST	HW/STEAM	NONE	NORMAL
01 - 01	CATETERIA	BRICK	FIRE RESIST	HW/STEAM	NONE	NORMAL

		VENEER				
01 - 01	MULTI-USE OFFICE	BRICK VENEER	FIRE RESIST	HW/STEAM	NONE	NORMAL
02 - 02	MULTI-USE OFFICE	BRICK VENEER	FIRE RESIST	HW/STEAM	NONE	NORMAL
02 - 02	MULTI-USE OFFICE	BRICK VENEER	FIRE RESIST	HW/STEAM	NONE	NORMAL
03 - 03	MULTI-USE OFFICE	BRICK VENEER	FIRE RESIST	HW/STEAM	NONE	NORMAL
B1 - B1	LIGHT MANUFACTURING	N/A	FIRE RESIST	HW/STEAM	CENTRAL	

Commercial Property Card

Print Date: 4/24/2017

Card 5 of 6

<<Back Next>>

Account 261906386767 E	Location 240 ORAL SCHOOL RD	Zoning RU-80	Deed Book/Page 90/426	Acres 77.39
District OLD MYSTIC	Use Code STATE			

Current Owner
CONNECTICUT STATE OF MYSTIC ORAL SCHOOL
9 ORAL SCHOOL RD
MYSTIC CT 06355

Property Picture

IMAGE NOT AVAILABLE

Building Information

Building No:	5
Year Built:	1930
No of Units:	1
Structure Type:	RES - 1 FAMILY
Building Total Area:	4809 sqft.
Grade:	B-
Identical Units:	1

Valuation

Land:	\$1,554,000
Building:	\$15,040,400
Total:	\$16,594,400
Total Assessed Value:	\$11,616,080

Recent Sales

Book/Page	Date	Price
-----------	------	-------

Building Sketch

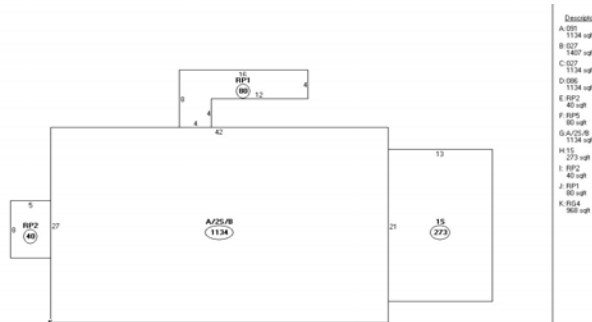

Sketch Legend

----	Main Living Area	ISMA	Masonry	GRHS	Attached Greenhouse
1FR	Frame	OMP	Open Masonry Porch	CAT	Cathedral Ceiling
OFP	Open Frame Porch	EMP	Enclosed Msry Porch	SOP	Screen Open Frame Prch
EFP	Enclosed Frame Porch	MUB	Masonry Utility	SMP	Screen Open Msrny Prch
FUB	Frame Utility Building	MB	Masonry Bay	CPAT	Concrete Pabio
FB	Frame Bay	MOH	Masonry Overhang	B	Basement
FG	Frame Garage	.SMA	1/2 Story Masonry		
FOH	Frame Overhang	MP	Masonry Patio		
.5FR	1/2 Story Frame	WD	Wood Deck		
A(U)	Attic (Unfinished)	CPY	Canopy		
A(F)	Attic (Finished)				

Exterior/Interior Information

Levels	Use Type	Ext. Walls	Const. Type	Heating	A/C	Condition
B1 - B1	UNFINISHED RES BSMT	N/A	WOOD JOIST	NONE	NONE	NORMAL
01 - 01	DWELLING	BRICK VENEER	WOOD JOIST	HW/STEAM	NONE	NORMAL
02 - 02	DWELLING	BRICK VENEER	WOOD JOIST	HW/STEAM	CENTRAL	NORMAL
A1 - A1	SUPPORT AREA	BRICK VENEER	WOOD JOIST	NONE	NONE	FAIR

Commercial Property Card

Print Date: 4/24/2017

Card 6 of 6

<<Back Next>>

Account	Location	Zoning	Deed Book/Page	Acres
261906386767 E	240 ORAL SCHOOL RD	RU-80	90/426	77.39
District	Use Code			
OLD MYSTIC	STATE			

Current Owner

CONNECTICUT STATE OF MYSTIC ORAL SCHOOL
 9 ORAL SCHOOL RD
 MYSTIC CT 06355

Property Picture



Building Information

Building No:	6
Year Built:	1976
No of Units:	1
Structure Type:	SCHOOL
Building Total Area:	52979 sqft.
Grade:	C+
Identical Units:	1

Valuation

Land:	\$1,554,000
Building:	\$15,040,400
Total:	\$16,594,400
Total Assessed Value:	\$11,616,080

Recent Sales

Book/Page	Date	Price
-----------	------	-------

Building Sketch

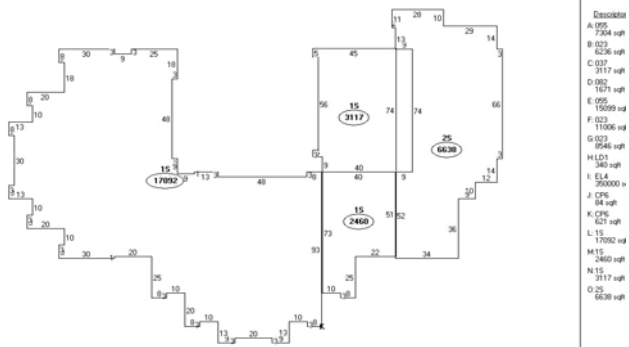

Sketch Legend

-----	Main Living Area	1SMA	Masonry	GRHS	Attached Greenhouse
1FR	Frame	OMP	Open Masonry Porch	CAT	Cathedral Ceiling
OFF	Open Frame Porch	EMP	Enclosed Msry Porch	SOP	Screen Open Frame Prch
EFP	Enclosed Frame Porch	MUB	Masonry Utility	SMP	Screen Open Msry Prch
FUB	Frame Utility Building	MB	Masonry Bay	CPAT	Concrete Patio
FB	Frame Bay	MOH	Masonry Overhang	B	Basement
FG	Frame Garage	.SMA	1/2 Story Masonry		
FOH	Frame Overhang	MP	Masonry Patio		
.SFR	1/2 Story Frame	WD	Wood Deck		
A(U)	Attic (Unfinished)	CPY	Canopy		
A(F)	Attic (Finished)				

Exterior/Interior Information

Levels	Use Type	Ext. Walls	Const. Type	Heating	A/C	Condition
01 - 01	SCHOOL	BRICK VENEER	FIRE RESIST	HW/STEAM	NONE	FAIR
02 - 02	DORMITORY	BRICK VENEER	FIRE RESIST	HW/STEAM	NONE	NORMAL

01 - 01	CATERIA	BRICK VENEER	FIRE RESIST	HW/STEAM	CENTRAL	GOOD
B1 - B1	MULTI-USE OFFICE	N/A	FIRE RESIST	HW/STEAM	CENTRAL	NORMAL
B1 - B1	SCHOOL	N/A	FIRE RESIST	HW/STEAM	NONE	POOR
01 - 01	DORMITORY	BRICK VENEER	FIRE RESIST	HW/STEAM	CENTRAL	GOOD
01 - 01	DORMITORY	BRICK VENEER	FIRE RESIST	HW/STEAM	NONE	FAIR